

MC

Elettropompe multistadio Multistage pumps Electropompes multicellulaires



MC

Multicellulare
Multicellular
Multicellulaire

60 - 80

Potenza motore
Motor power
Puissance moteur

M - T

M=monofase T=trifase
M=1 phase T=3 phase
M=monophasé T=triphase

◇ **UTILIZZO:** Elettropompe multicellulari orizzontali con una ottima resa idraulica e una buona silenziosità. Sono adatte ad usi civili, industriali, negli impianti di irrigazione, per gruppi autoclavi e stazioni di lavaggio. È consigliabile l'uso di liquidi chimicamente e meccanicamente puliti, con temperatura non superiore a 40°C.

POMPA: Corpo pompa e flangia di aspirazione in ghisa G20, camicia esterna e albero in acciaio inox, diffusori e giranti in Noryle e tenuta meccanica in ceramica/grafite.

MOTORE: Elettrico di tipo chiuso a ventilazione esterna, grado di protezione IP44. Classe di isolamento F. Nei motori monofase viene inserito un microtermostato in modo da evitare danni in caso di surriscaldamento. Per i motori trifase la protezione è a cura dell'utente.

TENSIONI: M: 230-240 V. 50 Hz; T: 230/400 V. 50 Hz. A richiesta sono disponibili tensioni e frequenze diverse.

◇ **SCOPE OF APPLICATION:** Multicellular horizontal pumps. These pumps feature excellent hydraulic performance, a very low noise while running, and are particularly suited for use in civil and industrial applications, in high pressure irrigation systems and car washing systems. It is recommended that these pumps are used to carry only chemically pure liquids and free of foreign matters, with temperature not higher than 40°C.

PUMP: Pump body and suction flange made of G20 cast iron, motor casing and shaft made of stainless steel, diffusers and impellers made of Noryl and ceramic/graphite mechanical seal.

MOTOR: Electric, closed-type with external cooling fan, IP44 protection degree. Class F insulation. The standard versions of single-phase motors are fitted with thermostat-controlled safety microswitches to avoid undesirable damages to the motor. The user must provide protection for three-phase electropumps.

TENSION: M: 230-240 V. 50 Hz; T: 230/400 V. 50 Hz. Different voltage and frequency ratings are available on request.

◇ **UTILISATION :** Pompes multicellulaires horizontales ayant un très bon rendement hydraulique et un fonctionnement silencieux. Ces pompes sont appropriées pour des utilisations privées, industrielles, pour les arrosages, pour groupes autoclave, pour autowashing. Lors de l'utilisation de ces électropompes il est conseillé d'employer des liquides chimiquement et mécaniquement propres et à des températures ne dépassant pas 40°C.

POMPE: Corps de pompe et brides d'aspiration en fonte G20, chemise extérieure et arbre en acier inox, diffuseurs et couronnes en Noryl et tenue mécanique en céramique/graphite.

MOTEUR : Electrique de type fermé à ventilation extérieure, degré de protection IP44. Classe d'isolation F. Dans les moteurs monophasés sont placés des microthermostats de sécurité pour éviter des regrettables dommages au moteur. La protection pour les électropompes triphasées est à la charge de l'utilisateur.

TENSION : M: 230-240 V. 50 Hz; T: 230/400 V. 50 Hz. Sur demande les tensions et les fréquences peuvent être différentes.

DIMENSIONI in mm. - DIMENSIONS in mm.

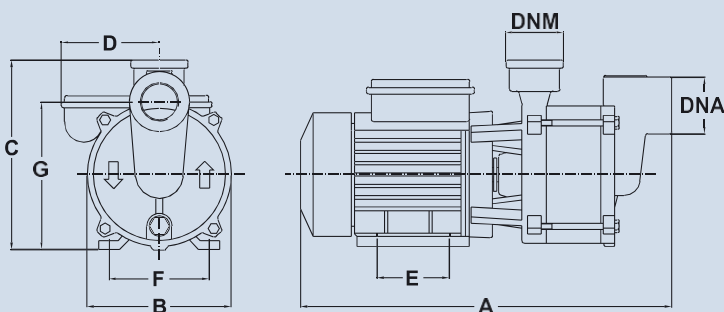

DIMENSIONI IMBALLO in mm - PACKING DIMENSIONS in mm
PESI - WEIGHT in KG.

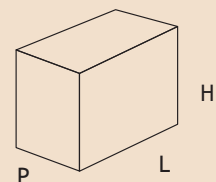

TIPO - TYPE	A	B	C	D	E	F	G	DNA	DNM	L	H	P	PESI - WEIGHT Kg	
													Pompa - Pump	Imballo - Pack
MC 60/3 M - T	335	120	165	80	80	100	123,5	1"	1"	390	195	180	8,3	0,5
MC 80/4 M - T	360	120	165	80	80	100	123,5	1"	1"	390	195	180	8,9	0,5

TIPO - TYPE		POTENZA POWER		AMPERE				PORTATA m³/h - CAPACITY m³/h				
MONOFASE 1/PHASE	TRIFASE 3/PHASE	HP	kW.	MONOFASE 1/PHASE		TRIFASE 3/PHASE		0	1,2	2,4	3,6	4,2
V. 230-240 50 Hz.	V. 230/400 50 Hz.			V. 230 240	µF	V. 230	V. 400	PORTATA Lt/Min. - CAPACITY Lt/Min.				
								0	20	40	60	70
PREVALENZA MANOMETRICA IN M.C.A. - TOTAL MANOMETRIC HEAD METRES												
MC 60/3 M	MC 60/3 T	0,6	0,44	3	12,5	2,3	1,3	32	26	19	9	4
MC 80/4 M	MC 80/4 T	0,8	0,6	4,2	16	2,6	1,5	43	36	27	16	10

Altezza massima di aspirazione: 7 metri. - Max suction depth: 7 metres.



COMPONENTI - ELEMENTS

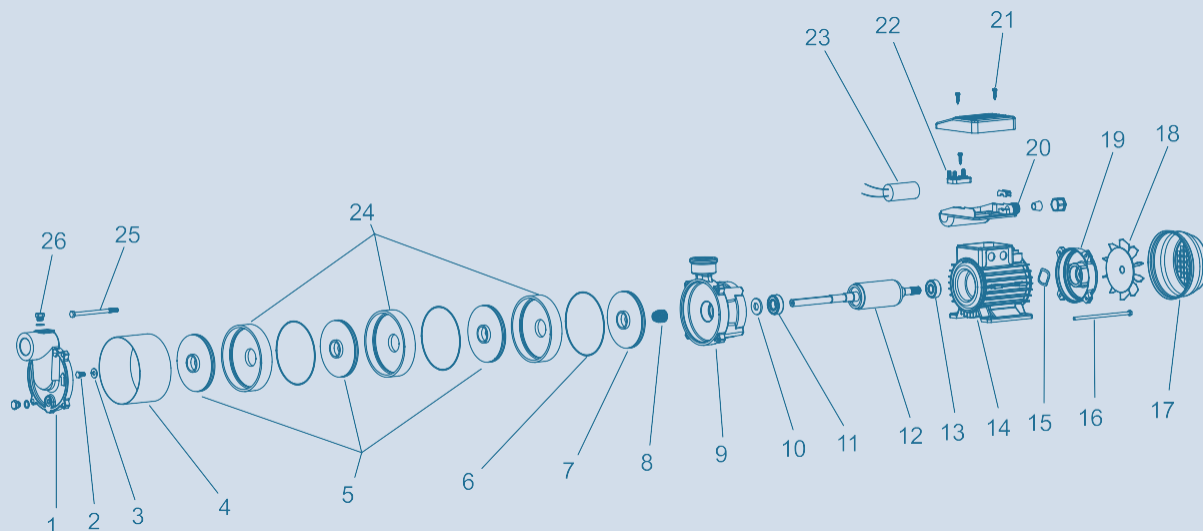

N	DESCRIZIONE - DESCRIPTION	MATERIALE - MATERIAL	N	DESCRIZIONE - DESCRIPTION	MATERIALE - MATERIAL
1	Corpo aspirante - Sucking body	Ghisa G20 - G20 Cast iron	14	Cassa motore + statore - Motor case + stator	Alluminio - Aluminium
2	Vite - Screw	AISI 316	15	Anello reggispira - Ring	Acciaio - Steel
3	Rondella - Washer	AISI 316	16	Tirante - Tie rod	FE 8.8
4	Camicia inox - Inox casing	AISI 316	17	Copriventola - Fan cover	Lega - Light alloy
5	Girante corto - Short impeller	Noryl	18	Ventola di raffreddamento - Cooling fan	Plastica - Plastic
6	Anello - O'ring	Gomma nitril. - Nitril. rubber	19	Scudo - Shield	Alluminio - Aluminium
7	Girante - Impeller	Noryl	20	Portacondensatore - Capacitor box	Plastica - Plastic
8	Tenuta meccanica - Mechanical seal	Ceram./Graf. - Ceram./graph.	21	Vite autofilettante - Self-threading screw	FE 8.8
9	Corpo pompa - Pump body	Ghisa G20 - G20 Cast iron	22	Morsetiera - Terminal box	Lega speciale - Special alloy
10	Paraspuzzo - Splash ring	Gomma telata - Rubber	23	Condensatore - Capacitor	Polipropilene - Polypropylene
11	Cuscinetto - Bearing 6202-ZZ	AISI 316	24	Gruppo diffusori - Diffusers' set	Noryl
12	Albero motore + rotore - Driving shaft + rotor	AISI 416	25	Tirante - Tie rod	FE 8.8
13	Cuscinetto - Bearing 6201-ZZ	AISI 316	26	Tappo 1/8" GAS - 1/8" GAS screw plug	Ottone - Brass

I valori descritti si intendono di produzione media. La Ditta si riserva di apportare qualsiasi variazione senza obbligo di preavviso.

The figures in the tables are averages for production models. The Company reserves the right to carry out changes of any kind without prior notice.